



# **assembly manual**

**Technical Data  
W Series  
Electronic Keyers**

AM 120 1st Edition (Part)

# 1 Table of Contents

1	Table of Contents .....	2
2	Table of Figures .....	2
3	Functional Description of the Electronic Keying .....	3
3.1	Building Blocks .....	3
3.2	Operation of the Circuits .....	3
3.3	Spontaneous Tone Attack .....	3
3.4	Soft Tone Attack.....	4
3.5	V. Sustain .....	4
3.6	Key-down Detector .....	6
3.7	Operation of the Gates.....	6
3.8	Keying Matrix.....	6
4	Testing of the PC boards H K 13 and H K 12.....	7
4.1	Preparations.....	7
4.2	Pre-Testing of the integrated Switches IC 1a and Transistors Q 1 on H K 13 .....	7
4.3	Testing of the Switching Functions on H K 13 .....	7
4.4	Testing of the Function "Soft Attack" on H K 13 .....	8
4.5	Testing of the Function "Sustain" on H K 13 .....	8
5	Testing of the PC Boards H K 1 2 .....	9
5.1	Preparations.....	9
5.2	Pre-Testing of the Integrated Switches IC 1 a and the Transistors Q 1 on H K 12.....	9
5.3	Testing of the Switching Functions on H K 1 2 .....	9
5.4	Testing of the Function "Soft Attack" on H K 12 .....	10
5.5	Testing of the Function "Sustain" on H K 12 .....	10
6	Testing of the daughter boards ET 12 and ET 13 .....	11
6.1	Required test equipment: .....	11
6.2	Preparation:.....	11
6.3	Test step 1: .....	11
6.4	Test step 2: .....	12
6.5	Test step 3: .....	12
6.6	Test step 4: .....	12
6.7	Test step 5: .....	12
6.8	Test step 6: .....	12
6.9	Test step 7: .....	13
6.10	Test step 8: .....	13
6.11	Test step 9: .....	13
7	Testing of the PC boards G 2 .....	14
8	Testing of the matrix boards.....	15

# 2 Table of Figures

Figure 1	Schematic diagram of the envelope control .....	3
Figure 2	Circuit diagram of gating circuits E T 12.....	4
Figure 3	Circuit diagram of the gating circuits ET13.....	5
Figure 4	Component layout and foil pattern (x-ray view) of the PC board H K 13 .....	7
Figure 5	Component layout and foil pattern (x-ray view) of the PC board H K 12 .....	9
Figure 6	Component layout and foil pattern (x-ray view) of the PC board ET 12 .....	10
Figure 7	Component layout and foil pattern (x-ray view) of the PC board ET 13 .....	11
Figure 8	Testing of the daughter boards ET 12.....	12
Figure 9	Testing of the daughter boards E T 13.....	13
Figure 10	Component layout and foil pattern (x-ray view) of the PC board G2 .....	14
Figure 11	Test hookup for the generator gating boards G2.....	14

### 3 Functional Description of the Electronic Keying

#### 3.1 Building Blocks

The electronic keying system consists of three functional subunits: key contacts - envelope control - gates. The key contacts and the envelope control circuits are assembled on the PC boards H K 12 and H K 13 respectively (Figure 5 and Figure 4). The assembled and tested circuit boards are then installed underneath the respective keyboards. The gates are assembled on the PC boards ET 12 and ET 13 respectively. The pre-tested boards will be inserted into one or more matrix boards, depending on the organ type.

#### 3.2 Operation of the Circuits

Figure 1 shows the circuit diagram of the envelope control.

The outlined portion of the circuit at the upper left-hand corner is used once per key, the balance only once per manual. First, a word about the electronic switches IC 1 a, IC 1 b, etc Each of these switches possesses an electrical path between an "input" and an "output", which is either inductive or non-conductive depending on the state of the control input. As long as the control input is at ground potential (even via a 100 kOhm resistor) the input-output path is conductive. Connecting the control input to -15 VDC causes the same path to be non-conductive. For all practical purposes you may assume that these circuits are solid-state relays. Four of these switches are packaged into a 14-pin IC (integrated circuit).

Figure 1 Schematic diagram of the envelope control

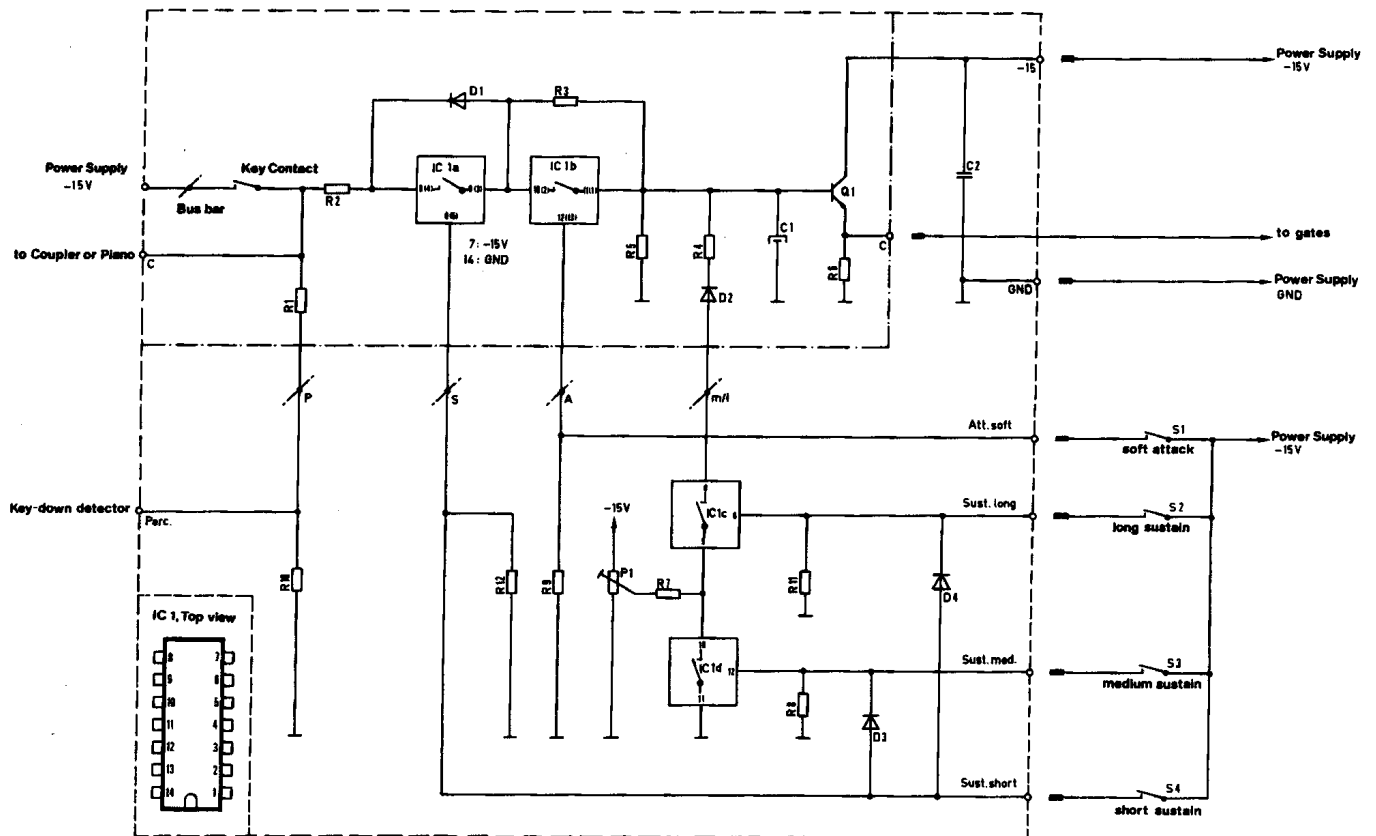

#### 3.3 Spontaneous Tone Attack

Suppose that the outboard control switches S 1 thru S 4 are open. The control inputs of the switches IC 1a thru d are connected to ground via 100 kOhms resistors; the switches are "closed". Depressing a key causes the negative key bus

voltage to pass through R 2, IC 1 a and IC 1 b and it will appear at the base of transistor Q 1, turning on Q 1. The output of Q 1 (taken from the point "C") swings to -15 V DC. This voltage is fed to the gates (

Figure 2 and Figure 3) which open abruptly. The keyed tones (up to 13 in a large organ) will appear suddenly. C 1, by the way, does not slow down this process, since the path through R 2 and the electronic switches has a very low impedance.

After the key is released again C 1 discharges rapidly via the electronic switches, R 2, R 1 and R 10, Q 1 is turned off and the corresponding keyer gates block the tones practically immediately.

### 3.4 Soft Tone Attack

A different situation exists if the switch S 1 "Soft Attack" is closed. IC 1 b is now "open". The charging and discharging of C 1 is slowed down by the additional resistance of R 3. Q 1

closes and opens more slowly which produces exponential rise and fall times of the gate control voltage; the tones appear with a soft build-up and decay with some sustain.

### 3.5 V. Sustain

If S 4 "Sustain Short" is closed IC 1 a opens. This has no consequences for the tone attack since IC 1 a is by-passed by the diode D 1. The discharge path, however, for C 1 now is determined by R 4, D 2 and the (closed) electronic switches IC 1 c and IC 1 d as well as R 5 in parallel. The values of the components are chosen to produce a noticeable sustain when the key is released.

Figure 2 Circuit diagram of gating circuits E T 12

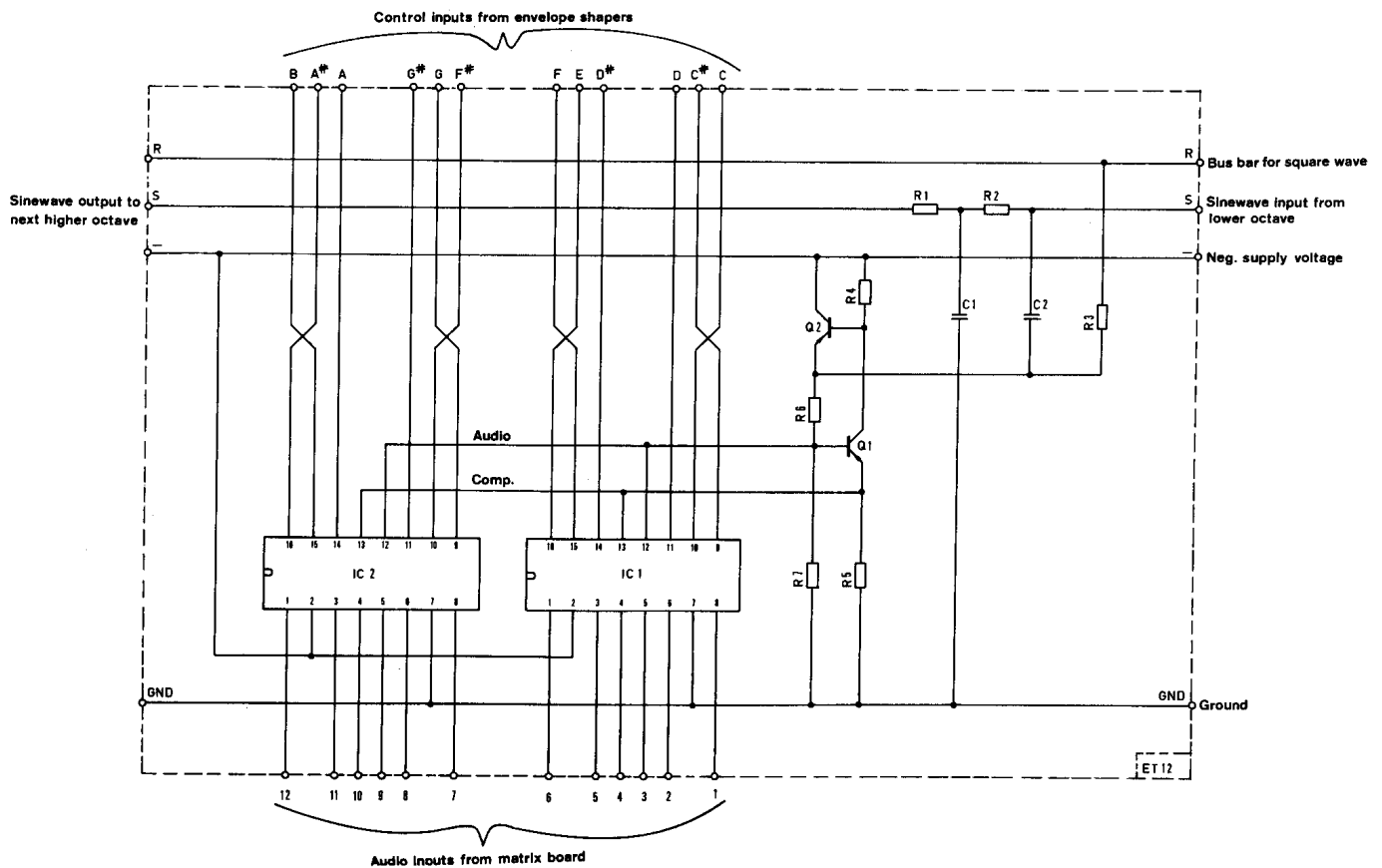
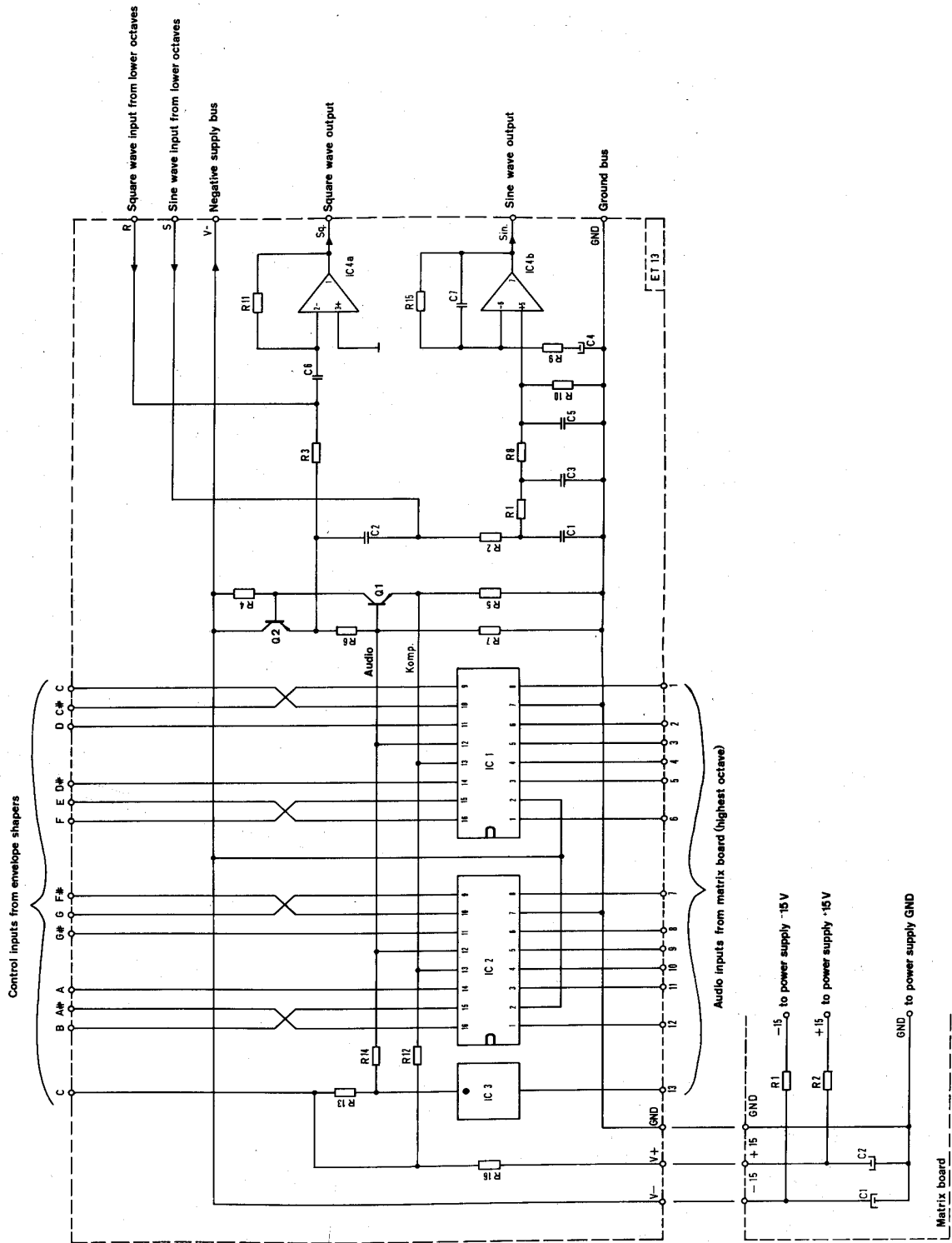

Figure 3 Circuit diagram of the gating circuits ET13



Additional lengthening of the sustain time is obtained by closing the switches S 2 and/or S 3. With S 3 closed, IC 1 d opens, adding R 7 and P 1 to the discharge path. This sustain time "Sustain Medium" is adjustable within certain limits by trimpot P 1. Closing S 2 "Sustain Long" reduces the discharge path of C 1 to R 5, producing the longest sustain.

### 3.6 Key-down Detector

Every time a key is depressed a certain negative voltage appears across R 10 and is fed to the point "Perc.". This signal is a key-down detector and is used to trigger the special effects channel or the rhythm unit elsewhere in the organ.

### 3.7 Operation of the Gates

The actual keying of the audio signals coming from the tone generator takes place in so-called gates. Depending on the size of the manual 49 or 61 gates are required for each footage. The gates are combined in groups of 6 in a proprietary and patented IC (IC 1 and IC 2). The highest tone of every footage is handled by a single gate (IC 3). The gating circuits are shown in

Figure 2 and Figure 3.

The gates pass on the audio signals from the tone generator to the bus "Audio" as long as the control inputs to the gates are driven negative. Furthermore, the amplitude of the passed-through audio signal is directly proportional to the magnitude of the control signal. Only those keyers which are open activate the corresponding tone generator outputs. That is a n interesting circuit trick, resulting in a very high signal-to-noise ratio of WERSI's organs.

The keyed and summed audio signal on the "Audio" bus is post-amplified by Q 1 and Q 2. Q 2 has a very low output impedance preventing interactions between the square wave bus and the sine wave bus.

The gating IC's also supply a D C voltage output to the bus "Comp." This voltage, applied to the emitter of Q 1 cancels the DC component inherent in the keyed audio signals such that the amplified audio signal swings symmetrically about ground potential. There are no "key-pop" in a W E R S I organ. Three or four PC boards "ET 12" are chained together and the square wave bus and sine wave bus are terminated on the 13-gate board "ET 13". The gates on ET 13 contribute the signals of the highest 13 notes.

The summed square wave signal is amplified and isolated by the operational amplifier (op amp) IC 4 a and is fed to the terminal "Sq." from where it will be taken for the various voicing filters.

The signal on the sine wave bus is pre-filtered by C 1, C 2, R 1 and R 2 on every board ET 12 and on ET 13. R 8, R 10, C 5 and C 7 on ET 13 produce further low pass filtering of the-summed signal which then is amplified by op amp IC 4 b. This sine wave signal is used to feed the drawbar system.

### 3.8 Keying Matrix

An organ produces more than one tone per key as opposed to a piano. The single key contact has to operate up to 13 (sometimes more) gates. A special tone distribution system, the so-called keying matrix, assigns the "proper" tones to the gates. In the smallest WE RS I organ, the 96 tones from the tone generator are fed to 539 gates (2619 gates in the largest organ!). The wiring between the gates which are to use the same generator tone is accomplished with a printed circuit board, the keying matrix board. The matrix board also serves as mother board for the gating boards ET 12 and ET 13. The Tables 2 and 3 below serve to illustrate the tone distribution system. Table 2 lists the tones and frequencies used in the organs. The nomenclatures used for the tones of the musical scale differ in various parts of the world. We use a sequential numbering system for all tones used in the organ. This should enable you to trace a particular tone through the circuitry. Table 2 lists these numbers in connection with two of the most popular tone scales. The frequencies listed are the mathematically exact values for the equally tempered scale. The minimal and non-audible deviations from using a Twelfth-Root-Two divider are neglected in the table. The tone number system has the advantage that the tone distribution listed in Table 3 becomes more transparent. It can be seen which tones are keyed and will be heard at every manual key (if the organ is equipped with the corresponding footages). Think as if like numbers in the matrix plan (Table 3) are connected with each other (for example, all numbers "73"). This "connector pattern" exists in reality on the matrix board in the form of printed circuits and a few wire jumpers. Table 3 lists a total of 20footages. Only certain combinations are selected for each organ type. At the upper end of a manual so-called repetitions are used for the highest pitches. The two uppermost octaves of a 2' stop are identical. Pitches higher than the 1' have even more repetitions. This method is also used in pipe organs. There it saves pipes and in electronic organs it saves in frequency generation. Consider a consequent non-repetitive tone system with 5-octave manuals and stops to 1/4' pitch. The highest "C" would have the tone number 145 with a frequency of 66,976.14 Hz which does not make much sense. The high pitch registers are never used as chromatic solo voices, they merely serve to add brilliance or color to the underlying "working" stops at pitches of 8', 4' and the like.

Figure 4 Component layout and foil pattern (x-ray view) of the PC board H K 13

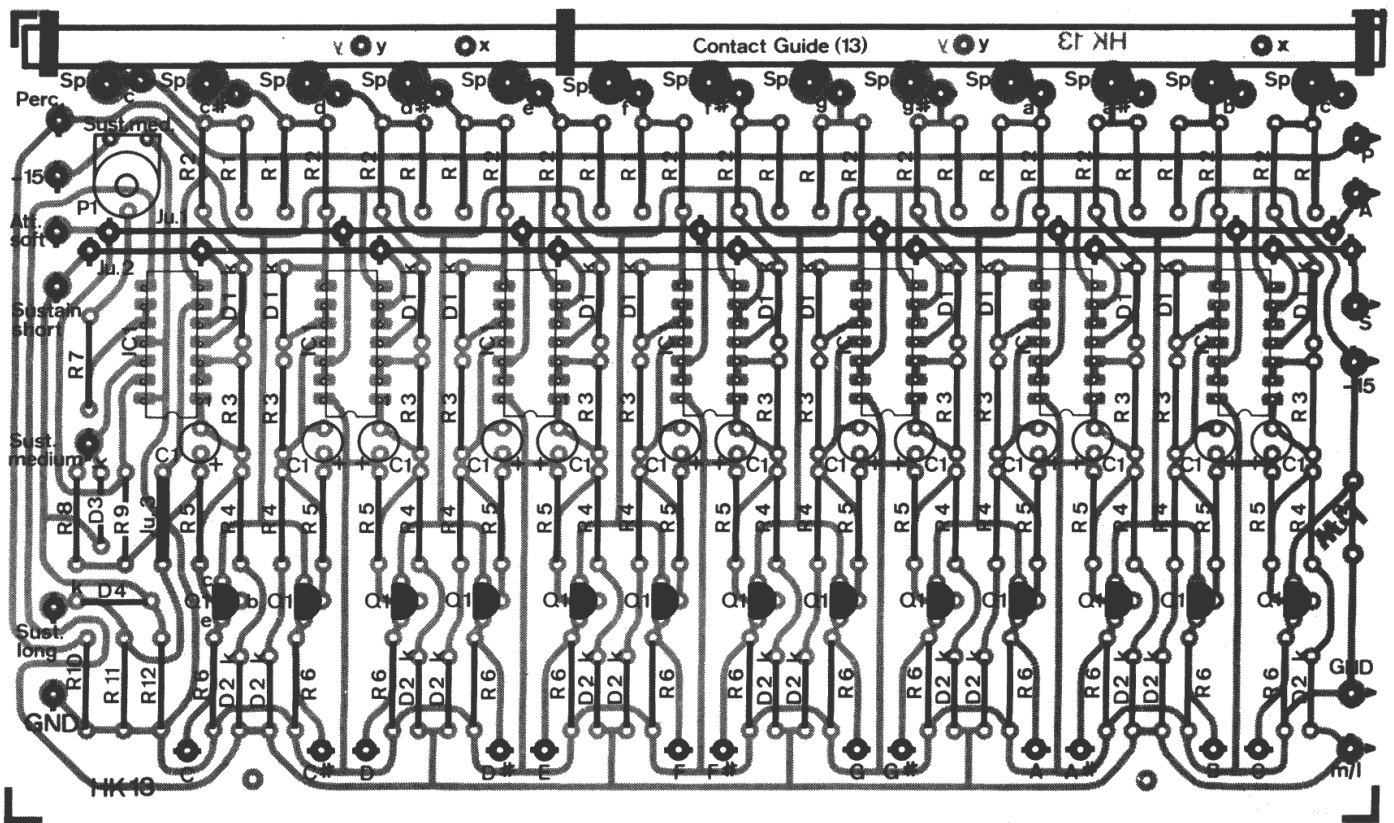

verify that the power supply voltage measures 15VDC +/-1VDC.

## 4 Testing of the PC boards H K 13 and H K 12

Prior to installing the PC boards H K 13 and H K 12 they have to be tested for proper functioning.

Test equipment required:

- Organ power supply which is tested and
- Voltmeter or multimeter with a range of approx. 25VDC.

Start with the testing of the PC board H K 13.

### 4.1 Preparations

- Using the thin stranded hookup wire (from bag #16), connect the pin "G N D" on H K 13 with one of the pins "G N D" of the power supply (Use the test connectors from Kit Pak 1, Power Supply and Generator).
- Connect the pin "-15" on H K 13 with one of the pins "-15" of the power supply.
- Connect the positive test lead of the voltmeter to "G N D" of the power supply. It will remain there during the complete test procedure.
- Turn on the power supply. Hold the negative (common) test lead to pin "-15" on H K 13 and

### 4.2 Pre-Testing of the integrated Switches IC 1a and Transistors Q 1 on H K 13

- Sequentially touch the pins "C", "C # ", "D ", etc. (capital letters) with the negative meter lead.
- None of these 13 points may indicate a voltage.
- Should you observe a voltage IC 1 a or Q 1 are suspect of being defective (see also Figure 1). We exclude the possibility of faulty soldering as an expression of our confidence in your quality workmanship.
- **Turn off** the power supply, pull the suspect IC straight out of its socket and turn on the power supply again. If the voltage does not re-appear the IC is defective. If the voltage persists Q 1 must be replaced. By the way, Q 1 and IC 1 associated with any of the output pins are located almost in line with the pin.

### 4.3 Testing of the Switching Functions on H K 13

- Connect the negative meter lead to the output pin "C". Be sure that the test lead does not touch the

neighboring resistor R 6, otherwise Q 1 will be destroyed.

- Turn off the power supply. Solder one end of a 30 cm (12") long hookup wire to pin "-15" on H K 13.
- Strip the other end and tin the strands. Turn on the power supply. Sequentially touch all contact springs with the hookup wire. Touching the pin "c" should result in a meter reading of 15 V DC. Touching any other contact springs must not cause any meter reading. Swap IC's to isolate a possible faulty one (while power is off).
- Connect the negative meter lead to the output pin "C #". Sequentially touch all contact springs with the hookup wire.
- A meter reading of 15 V DC should be obtained when and only when the spring "c #" is touched.
- Repeat this test for all other outputs.
- Only touching the contact spring with the same label as the output pin should produce a meter reading.

#### **4.4 Testing of the Function "Soft Attack" on H K 13**

- Connect the negative meter lead to the output pin ..C, ..
- Connect the hookup wire (from "-15") to contact spring "c". The meter will indicate 15 VDC.
- Solder a second 30 cm (12") long hookup wire to pin "-15" while power is turned off temporarily.
- Touch the pin "Att. soft" with the other end of the second hookup wire and observe the voltmeter. The reading should drop by about 1 Volt as long as the pin is touched.
- Repeat this step by connecting the meter lead sequentially to all output pins and simultaneously connect one of the hookup wires to the associated contact spring. The meter reading should drop by about 1 Volt everytime the pin "Att. soft" is touched by the second hookup wire.

- Isolate possible trouble spots by swapping IC's (always while power is off).

#### **4.5 Testing of the Function "Sustain" on H K 13**

At this point in time, there are three wires soldered to pin "-15" on H K 13 (one wire to the power supply and two uncommitted wires).

- Solder the free end of one hookup wire to pin "Sust.long".
- Connect the meter lead to output pin "C".
- Touch the contact spring "c" with the second wire.
- The voltmeter should read 15 VDC. Remove the wire from the spring while observing the voltmeter. The reading should sink towards zero within approx. 3 to 4 seconds.
- Repeat this test for all other stages (meter lead to "C #", "D ", etc. and touching the associated spring contact.
- Should any one (but not all) stages not exhibit this slow voltage decay the associated diode D 1 is probably defective. If none of the stages show the slow decay IC 1 c (next to pin "Sustain short") or diode D 4 are subject to be defective.
- Remove the hookup wire from pin "Sust.long" and solder it to pin "Sust. medium". Repeat the voltage decay test for an arbitrary stage.
- The voltage decay should be somewhat faster. Turning the trim pot P 1 counterclockwise will shorten the decay time. (Possible fault areas: IC 1 d, near pin "Sustain short" and diode D 3.)

This completes the testing of the PC board H K 13. Remove all power supply leads, test wires and meter leads. Repeat the entire test procedure for your second and third PC board H K 13 if applicable.



Figure 5 Component layout and foil pattern (x-ray view) of the PC board H K 12

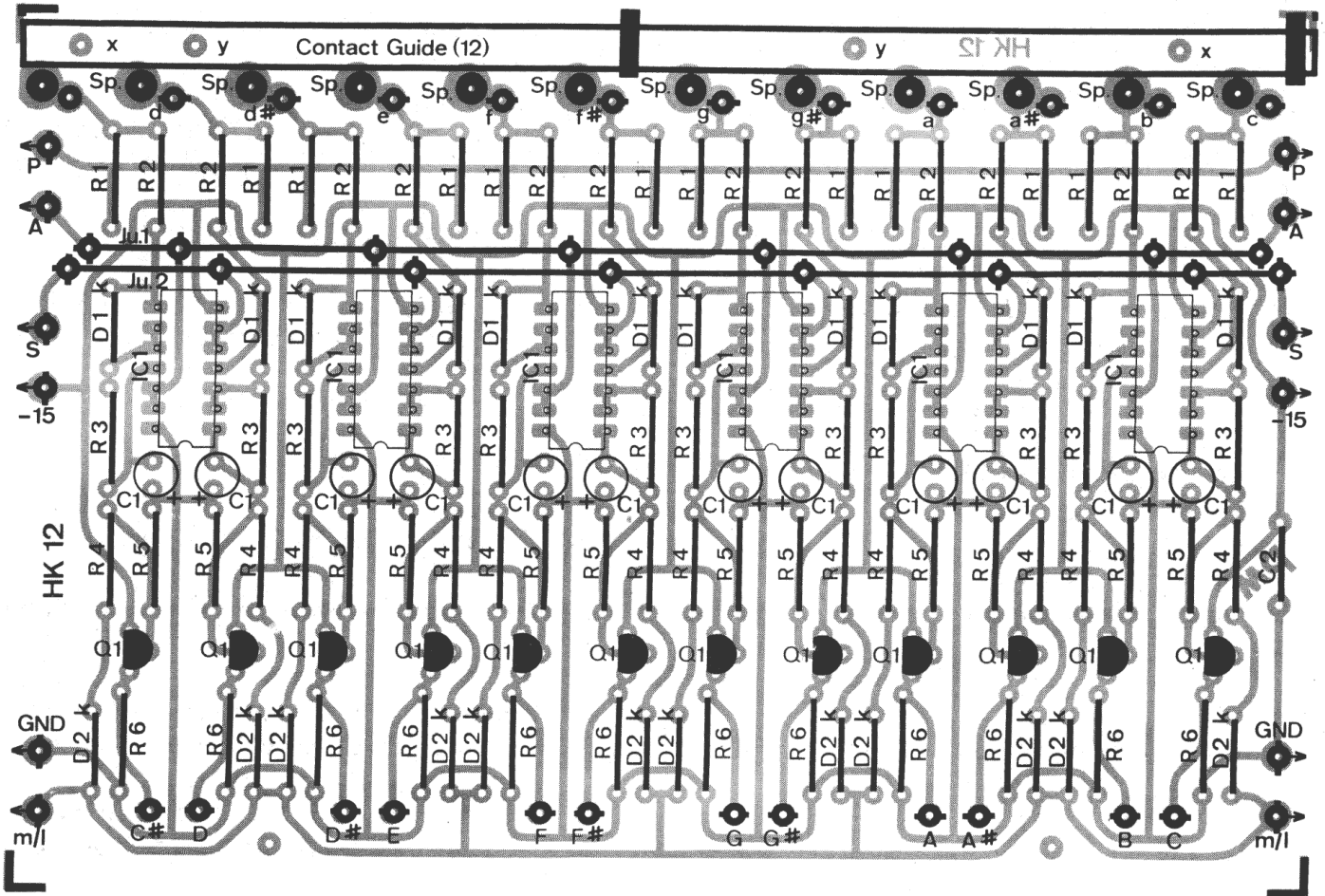

## 5 Testing of the PC Boards H K 12

The testing of the PC boards H K 12 is less involved than that for H K 13. Test one PC board H K 12 according to the procedure described below.

### 5.1 Preparations

- Connect the three pins "P", "G N D" and "m/I" of H K 12 to the power supply "G N D".
- Connect the pin "-15" on H K 12 with one of the pins "-15" of the power supply.
- Connect the positive meter lead to "G N D" on the power supply (will remain there during all tests).
- Turn on the power supply. Touch the pin "-15" on H K 12 with the negative meter lead. Verify the power supply voltage of 15 V DC.

### 5.2 Pre-Testing of the Integrated Switches IC 1 a and the Transistors Q 1 on H K 12

- Sequentially touch the 12 output pins "C #", "D", etc. with the negative meter lead.
- None of these 12 points should indicate a voltage.
- Should you observe a voltage, an associated IC 1 a or transistor Q 1 are suspect of being defective Swap IC's or replace Q 1.

### 5.3 Testing of the Switching Functions on H K 12

- Solder a 30 cm (12") long hookup to pin "-15" on H K 12.

- Connect the negative meter lead to output pin "C #". Sequentially touch the 12 contact springs with the hookup wire.
- The meter should indicate 15 V DC when and only when the spring "c #" is touched.
- Repeat this test for all output pins. Only touching the contact spring in line with the output pin should result in a meter indication.

#### 5.4 Testing of the Function "Soft Attack" on H K 12

- Connect the negative meter lead to pin "C #".
- Connect the hookup wire to contact spring "c #".
- The meter will indicate 15 V DC.
- Solder one end of a second hookup wire to pin "-15" on H K 12 (while power is off).
- Touch the pin "A" (between pins "P" and "S") with the second hookup wire while observing the voltmeter.
- The voltage should drop by approximately 1 Volt as long as pin "A" is touched,
- Repeat this step for all other stages by connecting the meter lead sequentially to the output pins and simultaneously connecting the first hookup wire to the associated contact spring. Every time, touching

pin "A" with the second hookup wire should result in a 1 Volt drop of the meter reading.

#### 5.5 Testing of the Function "Sustain" on H K 12

- Temporarily remove the wire connected to pin "m/I" on H K 12 only.
- Solder the free end of one hookup wire from pin "-15" to pin "S" on H K 12 (while power is off).
- Sequentially touch each contact spring with the second hookup wire while the negative meter lead is connected to the associated output pin.
- The voltmeter should indicate 15 V DC as long as the spring is being touched and the meter reading should decay slowly (3 to 4 seconds) upon removal of the hookup wire from the spring (Possible fault location: associated diode D 1).
- Re-connect the hookup wire from "G N D" of the power supply to pin "m/I" on H K 12.
- Repeat the preceding step for all stages.
- This time, the voltage should drop rapidly upon removal of the hookup wire from the contact spring. (If the decay is slow, investigate diode D 2).

Figure 6 Component layout and foil pattern (x-ray view) of the PC board ET 12

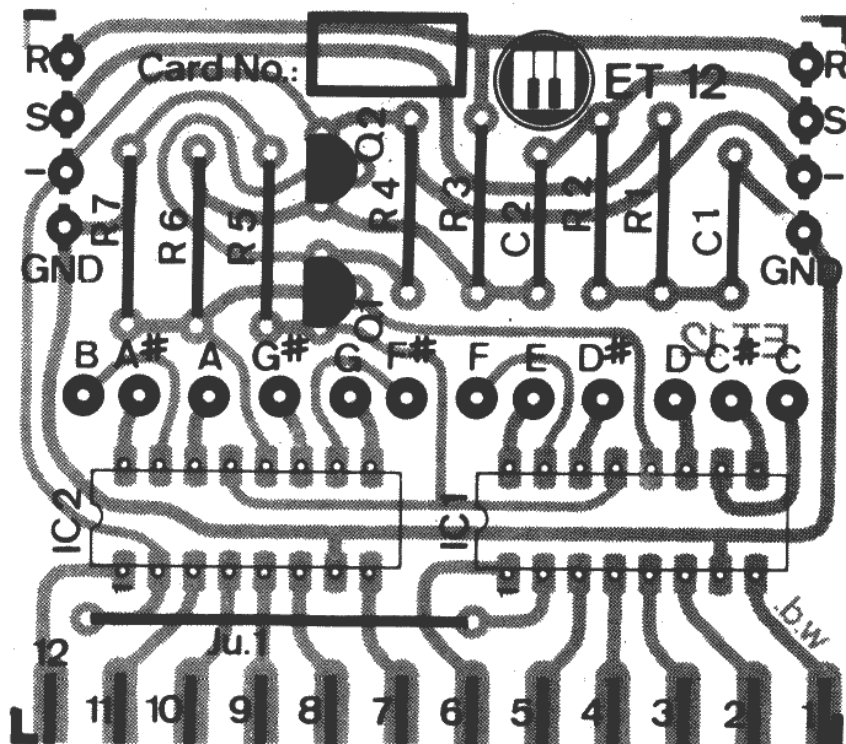
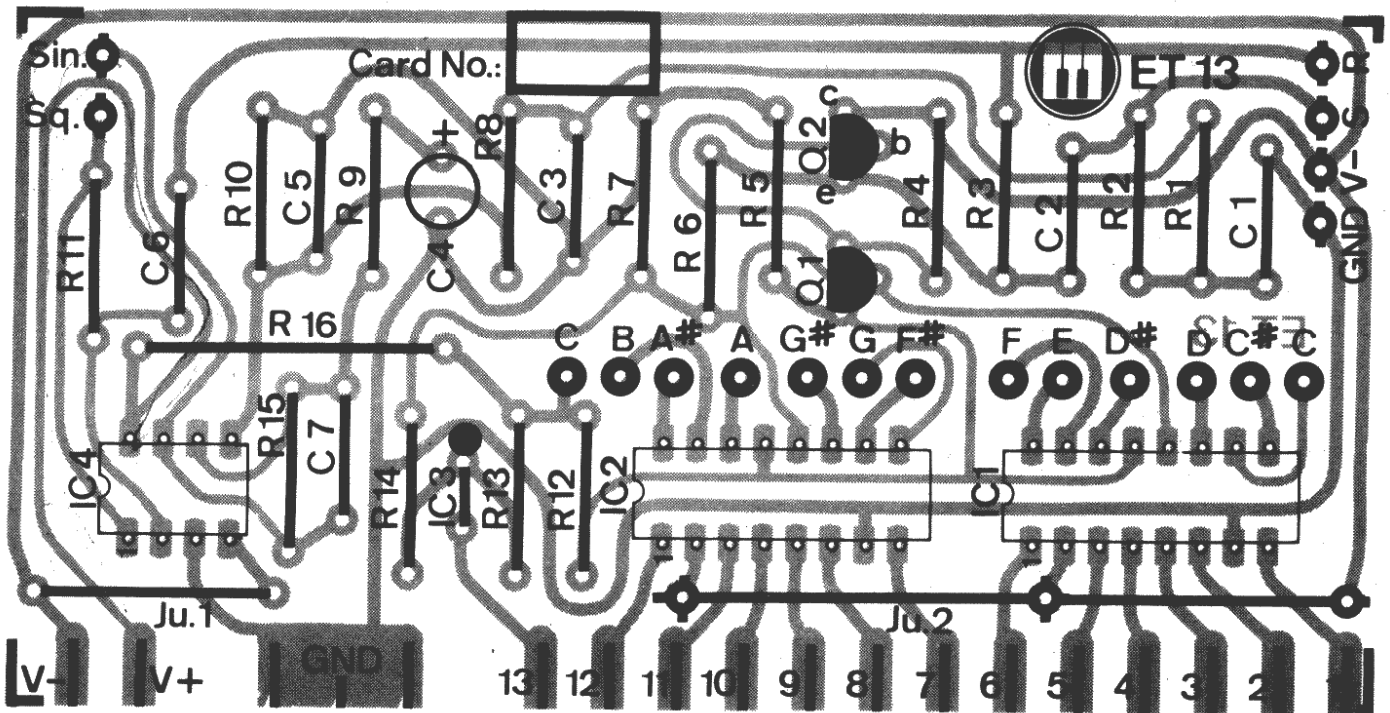

Figure 7 Component layout and foil pattern (x-ray view) of the PC board ET 13



## 6 Testing of the daughter boards ET 12 and ET 13

Before you proceed with the installation of the daughter boards on the matrix board(s) the plug-in boards must be tested. Check first all boards again for proper soldering and compare the component values with the appropriate partslists. Then, check each board for proper operation following the procedures below.

### 6.1 Required test equipment:

- Tested organ power supply (+15 VDC and -15 VDC)
- Tested tone generator
- Audio amplifier (organ amplifier with speaker, stereo set, portable radio with tape or record player input)
- Voltmeter or multimeter (with a range of approx. 15VDC).

### 6.2 Preparation:

Set up power supply, tone generator and amplifier according to the respective assembly manuals.

**Warning:** There are going to be some AC line voltage terminals exposed in your test set-up. Since the test gear is likely to be around for some time, cover all exposed AC wires and terminals with insulating material to eliminate any shock hazard.

Clean your work area of all debris left over from the assembly. Do not test the boards on a conductive surface.

### 6.3 Test step 1:

Place any of the PC boards ET 12 on your work surface. Referring to Figure 8, connect the wires #1 thru 8 permanently to power supply, tone generator and amplifier. Temporarily solder the wires #1, 2 and 6 also to the board under test. Terminate the wires #7 and 8 with alligator clips (from the tone generator kit). You find hookup wires and the 100 kOhms in bag #21 of Kit Pak 2.

Figure 8 Testing of the daughter boards ET 12

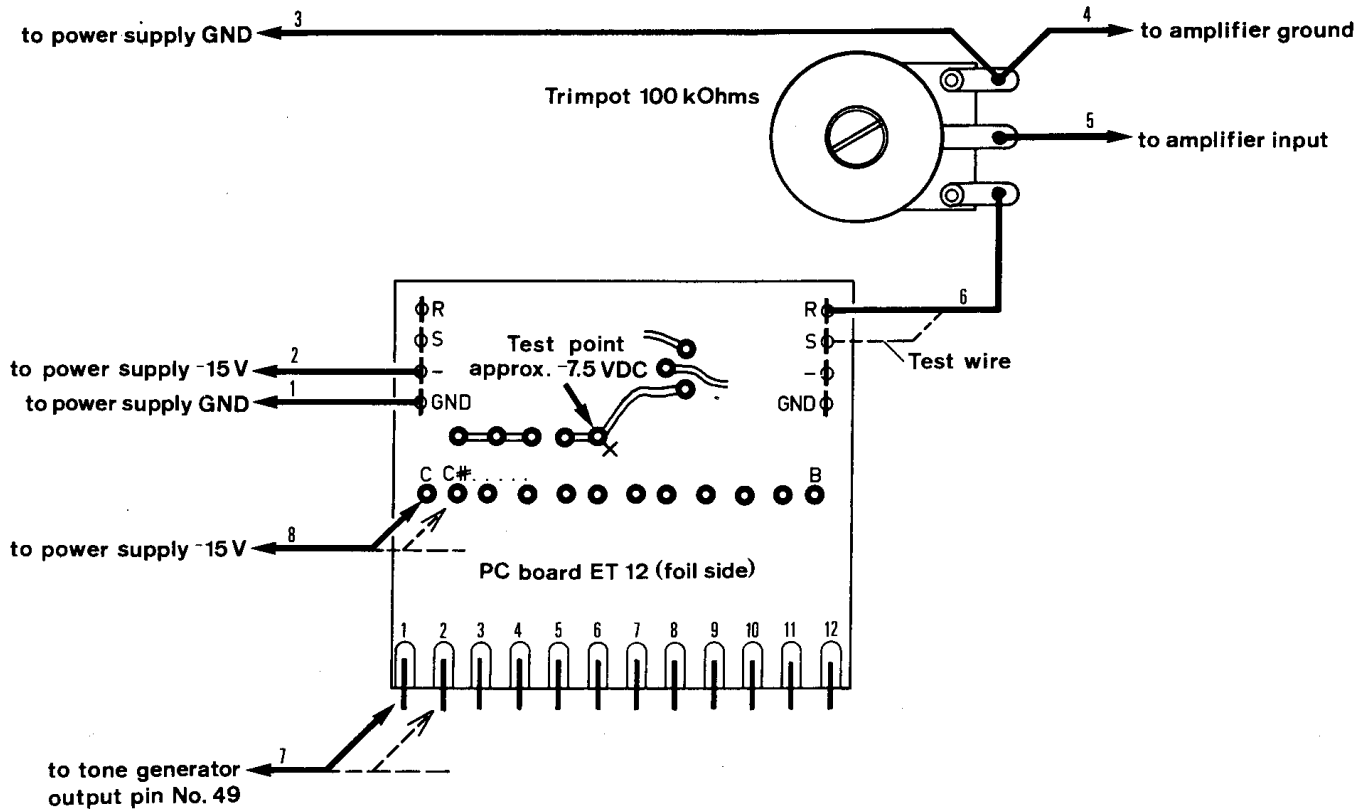

#### 6.4 Test step 2:

- Connect the positive meter lead to "G N D" and the negative (common) lead to point "x" (see Figure 8).
- (The voltmeter should have an impedance of 20,000 Ohms per Volt or more). Turn on the power supply. The meter should indicate 7.5 V DC  $\pm$  20%.
- In addition, turn on the amplifier. Clip wire #7 to pin 1 of the board under test. There should be no tone heard from the speaker (except for some possible leakage).

#### 6.5 Test step 3:

- Hold wire #8 (coming from "-15" on the power supply) to point "C" on the board under test. You should hear the tone coming from the tone generator. Adjust the volume to suit by means of 100 kOh ms trimpot. (If you don't like the tone we suggested - 261.626 H z - select another generator output).

#### 6.6 Test step 4:

- Move wire #7 to pin "2" and touch the location "C #" with wire #8. The tone should be heard when and only when pad "C #" is touched.
- Similarly, test all other pins from "D" thru "B".
- You may notice that the volume increases slightly while checking pins 1 thru 12.

#### 6.7 Test step 5:

- After testing all 12 pins, remove wire #6 from the pin "R" and solder it to pin "S". Repeat test step 4 for an arbitrary pin and pad. The tone will be heard at a lower volume and should have a softer character.

#### 6.8 Test step 6:

Repeat test steps 2 thru 5 for all other boards ET 12. We realize that this is a rather time consuming job but please consider the time involved if you would have to remove a faulty daughter board from the completed keyer assembly. The following test steps apply to the boards ET 13 only.

Figure 9 Testing of the daughter boards E T 13

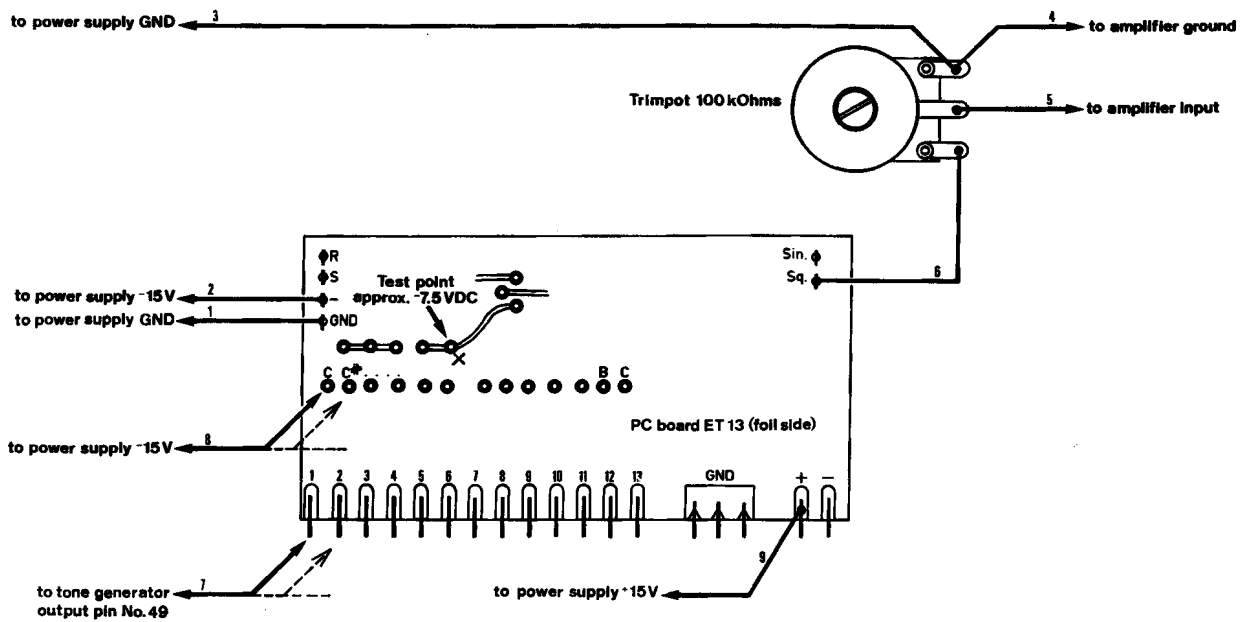

**6.9 Test step 7:**

- Connect one of the boards ET 13 to your test gear, referring to Figure 9. Note the additional wire #9 from the "+15" of the power supply to "+" on the board under test.

**6.10 Test step 8:**

- Repeat test steps 2 thru 5, however, this time for 13 pins and pads. Remark: While testing pin 13 on ET 13 without R 16 the tone may be heard even before the associated pad "C" is touched. This is normal, the

effect will disappear after subsequent installation of the board on the matrix board.

**6.11 Test step 9:**

- After testing these functions, remove wire #6 from pin "Sq" and solder it to pin "Sin" on the board under test. Repeat test step 4 for an arbitrary pin and pad. The tone will be heard at a lower volume and should have a softer character.

This completes the testing of the plug-in boards E T 12 and ET 13.

Figure 10 Component layout and foil pattern (x-ray view) of the PC board G2

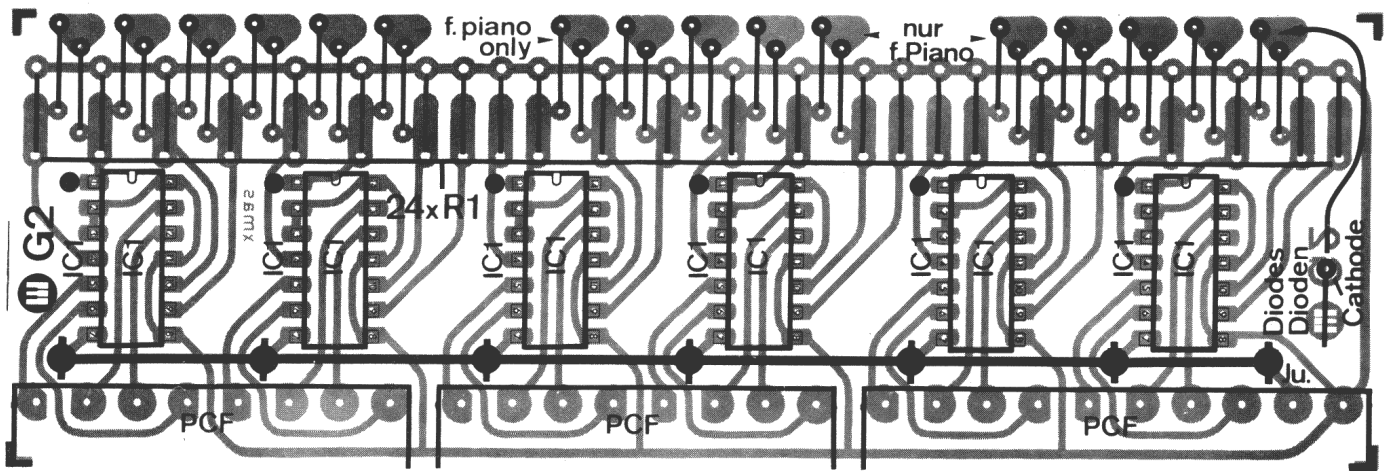

## 7 Testing of the PC boards G 2

- Referring to the assembly manual AM 1 00 "Precision Master Generator", set up the tone generator for operation.
- Insert 4 PC boards G 2 onto the connector pins of row 1 of the tone generator.
- Set up the test hookup as shown in Figure 11.
- Clip the test wire "A" to "-15 V".
- Sequentially touch all output pads on the plug-in boards G 2 (oblong foil pads near the top of the board) with the test wire "S".
- You should hear all 96 tones. (The trimpot serves to adjust the volume from your loudspeaker.)
- Remove test wire "A" from "-15 V" and clip it to "GND".
- Sequentially touch all output pads on the plug-in boards G 2.
- No tones should be heard. In case of difficulties swap integrated circuits on the plug-in cards. (Each IC contains four electronic switches.)
- If applicable, test additional plug-in boards G 2 by using pin row 2 (or 3) on the tone generator.

Figure 11 Test hookup for the generator gating boards G2

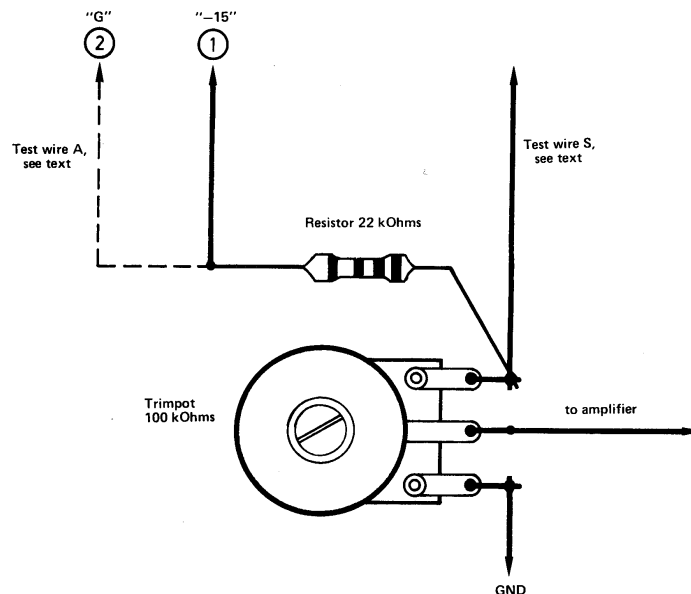

## 8 Testing of the matrix boards

In view of the large number of solder joints and conductors on the matrix board we recommend that you perform the following two series of tests:

- a) Test for unwanted connections between the copper conductors and ground
- b) Test for unwanted connections between neighboring copper conductors  
Clip one test lead of your ohmmeter to "G N D". Sequentially touch all tie points of the wiring harness with the other meter lead. There should be no direct connection to ground (less than 100 Ohms) of any harness wires. In case of a short

circuit to ground check the matrix board and the daughter boards along the suspect copper pattern for solder bridges. A "favored" spot for such bridges is located on the daughter boards, namely where the somewhat wider copper pattern "G N D " traverses the integrated circuits (see Figure 6 and Figure 7).

- Check neighboring wiring harness tie points for unwanted connections by touching the solder joints in pairs (i.e. 13 against 14, 14 against 15, etc. thru 107 against 1081. Again, in case of a short circuit check the matrix board and the daughter boards for solder bridges.

© 1999 Thomas Erlebniswelt Musik

This document has been reproduced for the benefit of current owners of WERSI organs. It should not be used for any commercial purposes.